

ME

series

Diaphragm Metering Pumps

OBL's largest mechanical diaphragm metering pump.

- Capacity to 1500 LPH (396 GPH)
- Max pressure to 7 bar (100 PSI)

Benefits from OBL's 22 years experience in mechanical diaphragm (multilayer, proven, robust, flat).

600 ÷ 1500 l/h



Diaphragm Metering Pumps

TECHNICAL FEATURES AND BENEFITS

- Few strokes/1' (ranging from 60 up to 123) allow handling of higher viscosity, suction lift and longer diaphragm life compared to other manufacturers.
- Better performance (reaching higher working pressures at the same flow rates (e.g. 1000 liters per hour @ 7 bar g max pressure).
- Limited number of pump head components (one size diaphragm fits all, same valves and valve seats throughout the range), result: less number of parts to procure and stock.
- Threaded and flanged connections available.
- 1% scale dial hand-wheel for accurate settings and improved repeatability, electrical and pneumatic actuator on demand.
- ATEX rated for Zone 2 category 3.
- IEC and NEMA motorization available.
- Light robust black anodized aluminum casing.

PUMP HEADS



Flanged connections



Threaded connections

MATERIALS OF CONSTRUCTION

PARTS	PP	P	A
PUMP HEAD	PP	PVC	AISI 316L
DIAPHRAGM	PTFE	PTFE	PTFE
VALVE GUIDE	PP	PP	AISI 316L
VALVE SEAT	PVC	PVC	AISI 316L
VALVE	PYREX	PYREX	AISI 316L
O-RING	FPM	FPM	FPM

On demand PTFE, Ceramic and Hastelloy-c valves.

TECHNICAL DATA

- Casing** • Anodized aluminium
- Stroke length** • 10 mm
- Weight** • 50 + 15 Kg
with EExd motor
- Flanges** • EN 1092-01
ANSI B16.5
- Motors** • IEC - 1,5 - 2,2 kw
230/400-3-50Hz
460/480-3-60Hz
IP55

MAX OVERALL DIMENSIONS

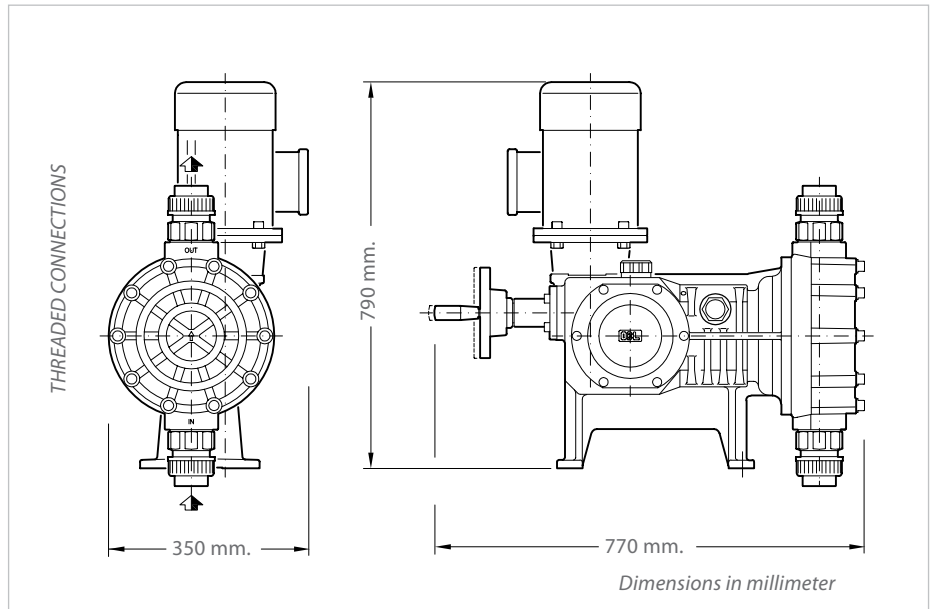

TECHNICAL CHARACTERISTICS

MODEL	STROKES/1'	FLOW RATE l/h *	MAX PRESS. bar				CONNECTIONS					
			1,5 kw		2,2 kw		PP			P-A		
			OPER.	MAX	OPER.	MAX	THREADED	FLANGED		FLANGED		
								EN 1092-01 DIN	ANSI	EN 1092-01 DIN	ANSI	
50 Hz												
ME 750	60	750	5	6	6	7	1 1/2" BSPF	DN40 PN16	1 1/2" ANSI 150	DN40 PN16	1 1/2" ANSI 150	
ME 1000	82	1000	5	6	6	7	1 1/2" BSPF	DN40 PN16	1 1/2" ANSI 150	DN40 PN16	1 1/2" ANSI 150	
ME 1250	100	1250	4	5	5	6	1 1/2" BSPF	DN40 PN16	1 1/2" ANSI 150	DN40 PN16	1 1/2" ANSI 150	
ME 1500	123	1500	3	4	4	5	1 1/2" BSPF	DN40 PN16	1 1/2" ANSI 150	DN40 PN16	1 1/2" ANSI 150	
60 Hz												
ME 600	48	600	5	6	6	7	1 1/2" BSPF	DN40 PN16	1 1/2" ANSI 150	DN40 PN16	1 1/2" ANSI 150	
ME 880	72	880	5	6	6	7	1 1/2" BSPF	DN40 PN16	1 1/2" ANSI 150	DN40 PN16	1 1/2" ANSI 150	
ME 1200	96	1200	4	5	5	6	1 1/2" BSPF	DN40 PN16	1 1/2" ANSI 150	DN40 PN16	1 1/2" ANSI 150	
ME 1470	121	1470	3	4	4	5	1 1/2" BSPF	DN40 PN16	1 1/2" ANSI 150	DN40 PN16	1 1/2" ANSI 150	

* Flow rate values relevant to 1,5 bar g operating pressure; per each bar increase flow rate decreases by 1%.

OBL Mechanical diaphragm pumps full line

MB series > 1÷155 l/h

MC series > 100÷420 l/h



MD series > 1÷520 l/h



ME series > 600÷1500 l/h



Quality System ISO 9001 Certified

OBL s.r.l.

Via Kennedy, 12

20090 Segrate - MILANO - Italy

Tel. +39-02.269191

Fax +39-02.2133893

www.oblitalia.com

obl.info@idexcorp.com

IDEX
FLUID & METERING