

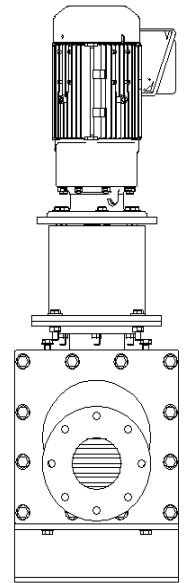

# DEFENDER

## THE GRINDER UNIT

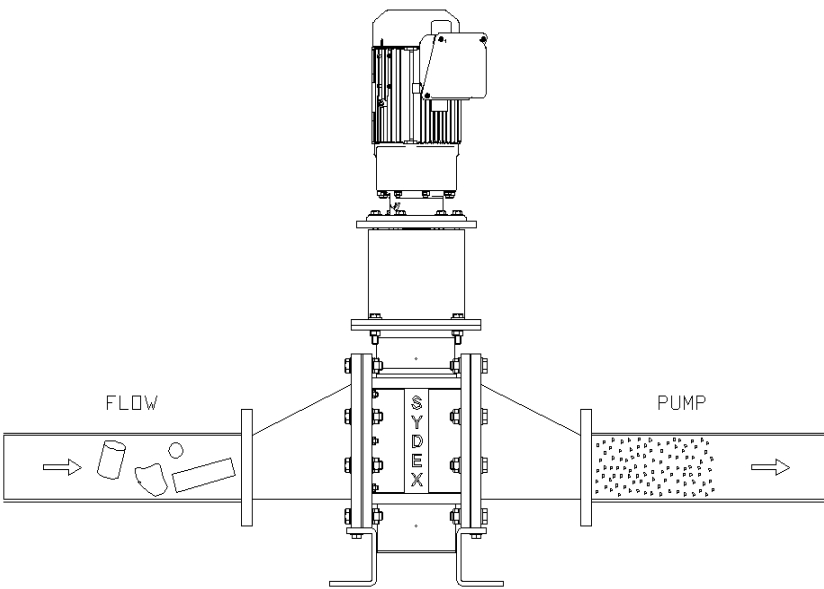



## FEATURES:

- Powerful chopper and grinding capabilities
- Prevents blockage and damage to any pumped system
- Reduces particle size down to 5-6 mm
- Highly effective combination of low speed and high torque
- Inline design
- Low head loss
- Cartridge design enables easy removal from pipework
- Channel version available
- Can be supplied with IP68 motor and mounting frame to protect submersible pumps
- Auto-reverse control panel for added protection

## MOTOR & GEARBOX:

- Rating: 2.2 kW motor power with output speed in between 100-110 rpm
- Heavy-duty proven Sumitono Cyclo geared motor

## MATERIALS:

- Cutters: heat treated steel
- Shaft: stainless steel

**SYDEX SRL** - Via Lord Baden Powell, 24 - 36045 Lonigo, Vicenza, Italy  
 Tel: + 39 0444 432 588 Fax: + 39 0444 432 589  
 E-mail : [info@sydexump.com](mailto:info@sydexump.com) Web : [www.sydexump.com](http://www.sydexump.com)